

THE PHOENIXTM SERIES

MODEL 1850 KNEE CPM OPERATOR'S MANUAL



www.mckelor.com

MCKELOR
TECHNOLOGIES, LTD.

6312 Seeds Road
Grove City, OH 43123
800.273.5233 Fax 614.871.9353

Phoenix Model 1850 Knee CPM Operator's Manual

Section 1

TABLE OF CONTENTS

	<u>PAGE</u>
Model 1850 Introduction	2-1
Safety Precautions	3-1
Unpacking your Phoenix Model 1850	4-1
Softgoods Application	5-1
Fitting the Patient	6-1
Bed Stabilization System	7-1
Pediatric and Petite Patient Adjustment	7-1
Phoenix Model 1850 Control Pendant Operation	8-1
Model 1850 Control Pendant Overview	9-1
Care & Cleaning	10-1
Product Specifications	11-1
Warranty Information	12-1
Service & Repair Return Instruction	12-1
Service & Maintenance Section 2	13-1
Quick Reference Guide	10-2

Phoenix Model 1850 Introduction



Thank you for choosing the **Phoenix Model 1850 Knee CPM** by MCKELOR TECHNOLOGIES, LTD.

The Phoenix Model 1850 provides effective continuous passive motion therapy to the post-operative or injured knee. The open carriage design provides a comfortable fit and accommodates adult and pediatric (petite) patient sizes. The control pendant is easy to understand and allows both staff and patient to change settings easily. Sturdy, mild steel construction, compact design and overall functionality make the Phoenix Model 1850 ideal for hospital and home environments.

Read before operating or adjusting the Phoenix Model 1850 Knee CPM.

It is recommended that all clinicians and support personnel responsible for the proper operation of the Model 1850 Phoenix Knee CPM become thoroughly familiar with its capabilities and proper operating procedures prior to actual patient use. Please contact customer service at 800-273-5233 with questions or visit our digital headquarters at www.imckelor.com for online training options.

Safety Precautions

1. Read and understand all instructions.
2. Follow all warnings and instructions marked on the product.
3. Connect power supply to grounded electrical outlets only. Use surge protector to further protect your unit.
4. Never touch any exposed or uninsulated wires or terminals unless the transformer has been unplugged.
5. Unplug this product from the wall outlet before cleaning. Do not use liquid or aerosol cleaners. Use only a damp cloth.
6. Do not use product near water.
7. This product should only be operated from the type of power source indicated on the label.
8. Do not allow anything to rest on the power cord. Do not place the power cord in a location where a person may trip, damage or move equipment over or near it.
9. Do not overload or use extension cords as this may result in the risk of fire or electric shock.
10. **If at anytime during the therapy the patient experiences extreme pain or discomfort-STOP-turn the unit off and consult their physician.**
11. Unplug the unit from the wall outlet and refer to qualified personnel under the following conditions:
 - If the power cord is damaged
 - If liquid is spilled into the product
 - If the unit has been exposed to rain or water
 - If the unit has been dropped or the frame has been damaged
 - If a change in performance is noted
 - If the unit does not operate normally by following the operating instructions
12. Adjust only the controls that are covered by the operating instructions.
13. **Warning:** Equipment not suitable for use in presence of a flammable anesthetic mixture with air, oxygen or nitrous oxide.

Unpacking your Phoenix Model 1850

When receiving your Phoenix Model 1850, examine the container and unit and report any substantial damage to the shipper. Do not discard your Phoenix shipping container - it provides required protection for your unit during shipping and must be used when returning your unit for any warranty service. Unapproved or badly damaged containers will be replaced and billed accordingly.

**Phoenix Shipping Carton
Part No. Skit 1824**

Container Contents

- > CPM Cradle Assembly with Control Pendant
- > Foot Cradle Assembly
- > Two (2) Bed Stabilizer Rods
- > One (1) Set of 1828-1 Phoenix Softgoods
- > Operators Manual, Quick Reference Guide, Training CD

Remove the Phoenix Knee CPM from the container and slide the Foot Cradle Assembly out. Loosen the large knobs on the Foot Cradle Assembly and position in the upright position. Tighten knobs.

Features

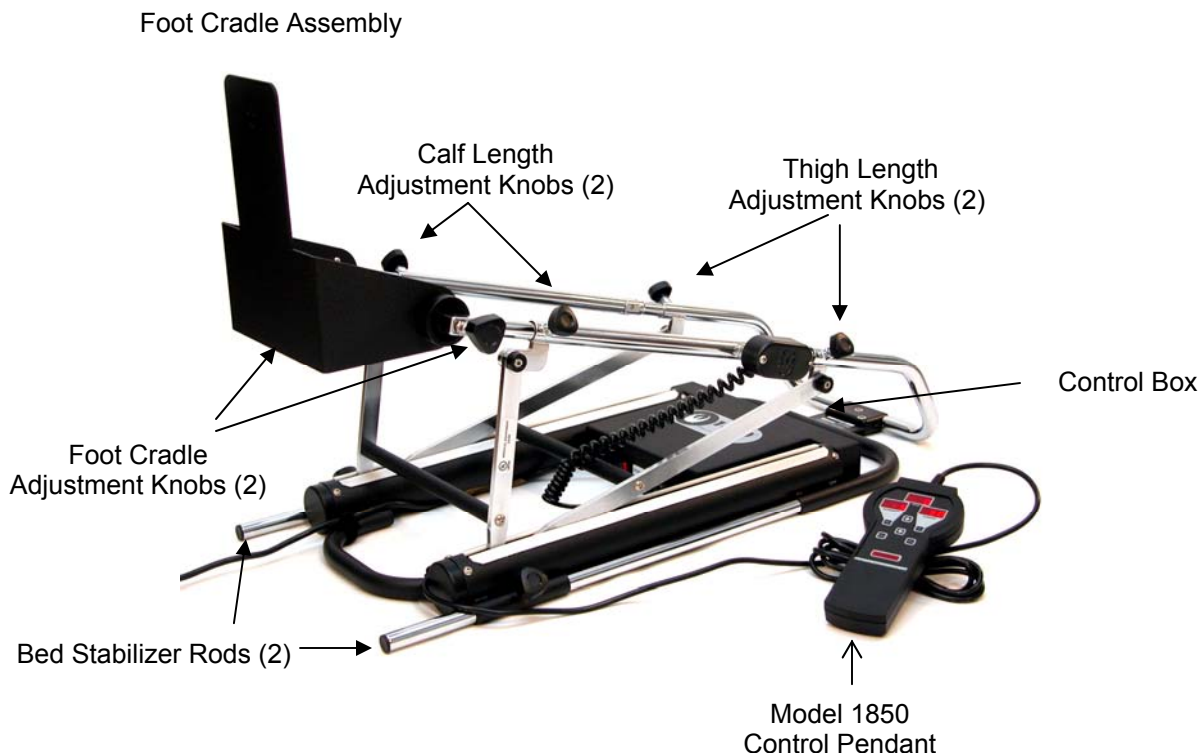

Softgoods Application

MCKELOR Softgoods - 1828-1 - are designed specifically for use with Phoenix Knee CPM models. They provide a 'troughing' effect allowing proper alignment of the limb and a truer fit overall. Constructed with the highest quality materials, MCKELOR softgoods provide superior comfort and support for the patient.

Each MCKELOR softgoods set includes five (5) pads total:

- 1 - Foot Boot
- 1 - Calf Pad
- 1 - Thigh Pad
- 2 - Auxiliary Straps

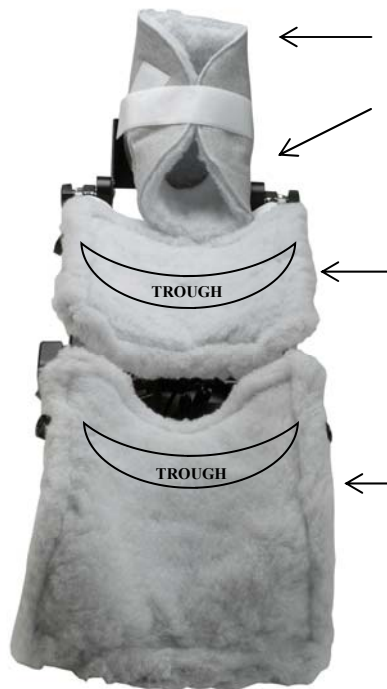

Slide the pocket of the foot boot over the end of the foot plate and secure to the velcro.

Secure ankle support straps on the foot boot to the foot assembly tubes on both sides.

The calf pad is the smaller of the two square-shaped pads. Position the calf pad so that the cut-out is facing the thigh cradle. Peel the velcro strapping from the back of the pad, loop over the cradle bar of the unit and secure to the back of the softgood. Be sure not to pull the softgood tight, forming a trough to allow for proper alignment.

The thigh pad is the larger of the two square-shaped pads. Position the thigh pad so that the cut-out is facing the calf pad (the cut-outs will form a 'diamond' shape). Begin with the tab Velcro at the very end of the thigh pad. Secure this piece to the bottom of the thigh block**. Peel the rest of the velcro strapping from the back of the pad, loop over the cradle bar of the unit and secure to the back of the softgood. Be sure to 'trough' the softgood, do not pull the softgood tight.

↑
** thigh block

The two (2) auxiliary straps may be used to secure the thigh and/or calf (do not secure too tightly...leave room for shifting).

MCKELOR softgoods are intended for single patient use only. Should the pads become soiled during use, spot clean by hand with mild detergent and warm water.

MCKELOR softgoods are designed specifically for use with the Phoenix Knee CPM Series. Use of any other brand of CPM Softgoods may adversely affect performance of the Phoenix Knee CPM and result in discomfort or injury to the patient.

Reorder number for the MCKELOR softgoods: 1828-1

Patient Setup

Correct measurement and adjustments are required to ensure patient comfort and compliance and to achieve desired range of motion. Check that the unit is at 0° during patient setup.

Note: Use only on a stable surface. An unstable surface could result in injury to patient and damage to the device.

FITTING THE PATIENT

- > Determine the length of the patient's femur by measuring from the greater trochanter (hip joint) to the center or joint line of the knee.
- > Transfer this measurement to the thigh cradle beginning approximately 1.5 to 2 inches away from the hip pivot assembly measuring to the knee axis of the unit. Adjust the thigh cradle to match this measurement by loosening the thigh adjustment knobs and sliding the thigh cradle to the proper length.
- > Loosen the calf cradle adjustment knobs and extend the foot assembly. Do not remove this assembly -- only slide far enough for patient placement. Position the patient's leg in the unit, with softgoods in place.
- > Slide the foot assembly toward patient accordingly leaving one half inch gap between the patient's foot and the foot plate. Tighten the calf cradle adjustment knobs securely.
- > The foot assembly may be adjusted in plantar flex or dorsi flex positions. Loosen the adjustment knobs on the foot assembly, adjust the foot plate to the desired positioning and securely tighten the adjustment knobs.

Remember: The goal is to align the knee axis of the patient with the knee pivot axis of the CPM

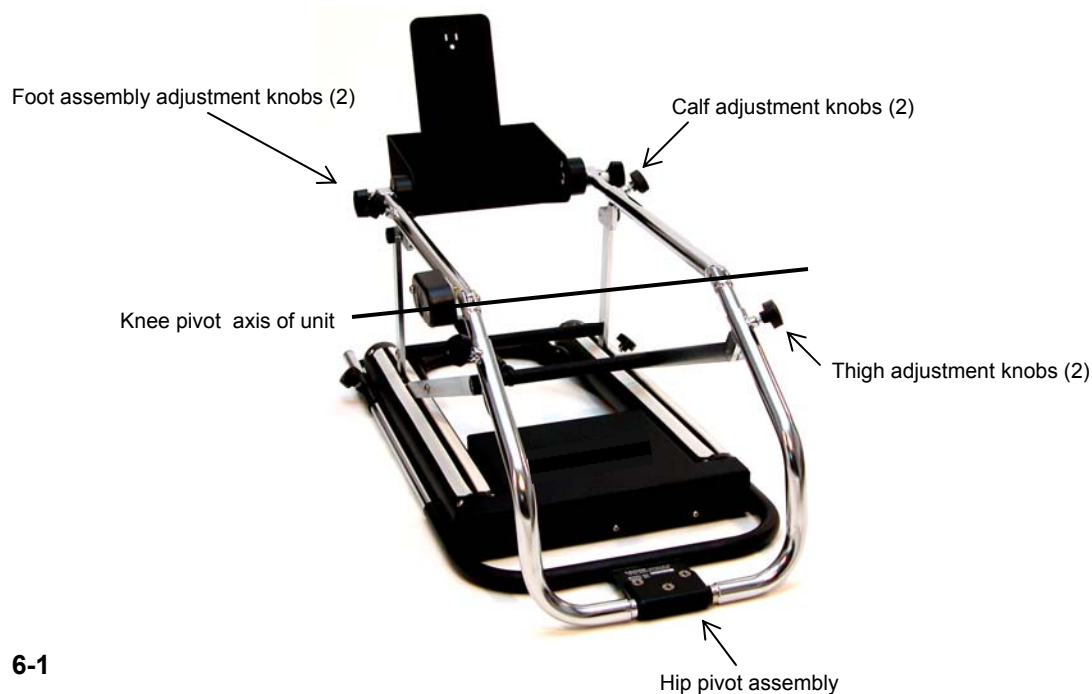

Patient Setup

BED STABILIZING SYSTEM

Bed stabilizer rods are included in the base of the Phoenix Knee CPM. This system, in conjunction with the non-skid pad located on the bottom of the control box, effectively prevents migration or "movement" of the unit while on a patient.

- > Loosen the base knobs, extend the rods to the appropriate length and tighten the knobs securely.
- > Stabilize the rods against a solid barrier such as a foot board.

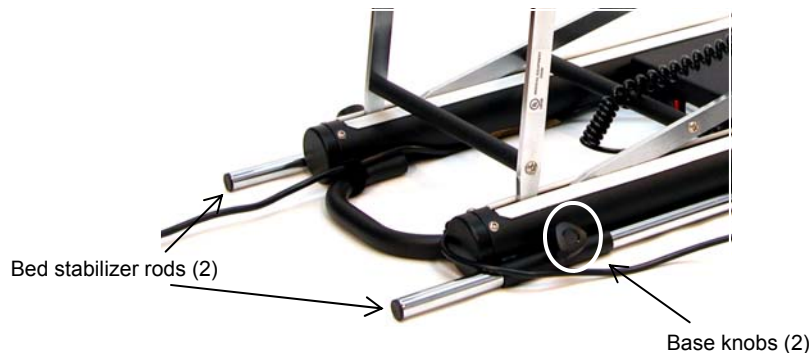

PEDIATRIC AND PETITE PATIENT ADJUSTMENT

The Phoenix Knee CPM can adjust easily to accommodate pediatric and petite patients.

- > Loosen the calf adjustment knobs and slide the foot assembly out of the cradle.
- > Loosen the foot assembly adjustment knobs (do not remove).
- > Rotate both foot tubes 180 degrees so that they are facing the opposite direction. Tighten the foot assembly adjustment knobs.
- > Slide cradle back into the Phoenix and secure with the calf adjustment knobs.
- > Note: You may apply a strip of adhesive-backed loop Velcro to this side of the footplate for added stability of the foot boot softgood.

Pediatric and Petite Patient Setup



Operating the Phoenix 1850 CPM

POWER ON AND OFF

The ON/OFF switch is located at the base of the black control box. When the unit is powered ON it will beep one (1) time and the hand-held control pendant will illuminate. This indicates that the unit is ready for use.

PHOENIX MODEL 1850 KNEE CPM CONTROL PENDANT

The Model 1850 control pendant includes of the following functionalities:

- Flexion: 0 to 110 degrees
- Extension: -5 to 105 degrees
- Speed: 1 degree per second at lowest setting, 3 degrees per second at highest setting
- Pause: 0 to 30 Seconds*
- Patient Compliance Meter
- Patient Lock Out Switch

> To set **Flexion** range: Depress the FLX button and the up ↑ or down ↓ arrow simultaneously.

> To set **Extension** range: Depress the EXT button and the up ↑ or down ↓ arrow simultaneously.

A 5 degree difference between flexion and extension is required for normal operation. Should the angle settings be too close the incorrect setting on the pendant will flash.

> To set **Speed**: Depress the Speed button and the up ↑ or down ↓ arrow simultaneously. When you depress the Speed button, the setting will appear in the ROM window.

> To set ***Pause**: Depress the Pause button and the up ↑ or down ↓ arrow simultaneously. When you depress the Pause button, the setting will appear in the ROM window.

> **Patient Compliance Meter**: The patient compliance meter monitors patient usage and tracks in tenths of an hour readings. Example: 25.4 reading = 25 hours and 24 minutes.

- Meter is displayed in the **Flexion** window
- The meter is read by depressing the **FLX** and **SPD** buttons simultaneously
- Clear meter by depressing the **EXT, FLX, SPD** and **Pause** buttons simultaneously.

Note: The Start/Stop button must be pressed in order to lock in setting changes.

PHOENIX MODEL 1850 CONTROL PENDANT OVERVIEW



Patient Lock-Out function:
The lock-out switch is located on the back of the control pendant under the plastic door cover. To prevent inadvertent changes to pendant settings, simply slide the switch to the locked position. The ROM window will read 'LOC' should attempt be made to adjust settings when this is in place. The stop/start button functionality remains the same.

*Pause option:

Phoenix Models are set to pause at the end of flexion and extension cycles. This setting can be changed to pause the Phoenix in extension only. See page 2-2 for details on this procedure.

CARE & CLEANING OF THE PHOENIX

Clean the Phoenix by using a mild disinfectant. Do not use aerosol cleaners or pour liquids directly on the unit. Use only a damp cloth.

Items listed below should be inspected, cleaned or replaced depending on their condition or appearance.

Cables:

- Potentiometer Cable
- Pendant Cable
- Power Supply Cable

Labels:

- Control Pendant Label
- Control Box Label
- Serial Number Label

Velcro:

- Footplate Velcro - 6"
- Plastic Hip Pivot Velcro—1" (Underneath)
- Control Pendant Velcro Strap
- Power Cord (Transformer) Velcro Strap
- Control Pendant Cable Strap

Skid Pads:

- Skid Pad under Control Box

Knobs & Screws:

- (4) Smaller Male Knobs for Thigh and Calf carriage adjustments
- (2) Large Female Knobs for Foot Plate adjustment
- (2) Smaller Male Knobs for Bed Mount Rods
- (4) Pendant Screws (Inside of Control Pendant)
- Check tightness of all Allan Head Screws on front & back End Caps

Track Seals:

- Clean & Check for tears - replace as needed

Clean:

- Chrome parts should be polished using a chrome cleaner and polish purchased at most automotive stores
- Wipe or clean all cords
- Clean outside of Control Pendant and other areas that are dirty

Product Specifications

Weight	26 Pounds
Length	28 Inches
Adjustable Length	42 Inches
Width	13 Inches
Range of Motion	-5 to 110 Degrees
Pause	0 to 30 Seconds
Limb Length	20 to 42 Inches
Calf Length	11 to 24 Inches
Thigh Length	9 to 18 Inches

- > Voltage 120 Volts AC input/60 Hz/14 Volts DC@.73 amp

- > ENVIRONMENTAL CONDITIONS FOR TRANSPORTATION AND STORAGE
 - Recommended Ranges:
 - Temperature range within -40° C to $+70^{\circ}$ C
 - Relative humidity range within 10% to 100%
 - Atmospheric pressure range within 500 to 1060 hPa

Warranty Information

LIMITED WARRANTY

MCKELOR Technologies, Ltd. (MCKELOR) warrants to the original buyer of this Phoenix Knee CPM series machine (the Unit) that the Unit will be free from defects in material or workmanship for a period of One Year from the date of original purchase from MCKELOR. This warranty does not cover defects resulting from damage by accident, abuse, misuse, misapplication, or unauthorized repairs or alterations made either by the customer or another party. MCKELOR reserves the right to determine whether the defective product falls into this category. MCKELOR makes no other warranties, expressed or implied (including, without limitation merchantability, fitness for a particular purpose, or against infringement of any patent), except expressly provided herein.

If the Unit does not conform to this warranty, MCKELOR will at its option repair or replace the defective Unit. The remedy of repair or replacement is purchasers' sole and exclusive remedy and will satisfy all of MCKELOR's liabilities, whether based on contract, tort, product liability, strict liability, or otherwise. In no event shall its liability in connection with any defective Unit exceed the sales price of such unit.

For this limited warranty to apply, buyer must provide MCKELOR with written notice of a claimed defect within thirty (30) days after the discovery, but no later than the expiration date of the warranty term. Within reasonable time following the receipt of such a notice, MCKELOR will advise the purchaser of the disposition of the Unit. Unless expressly authorized in writing, the defective Unit must be returned to MCKELOR for coverage. MCKELOR reserves the right to inspect the Unit to determine the claimed defect is within the coverage of this limited warranty.

www.mckelor.com

RETURNING YOUR PHOENIX FOR REPAIR

- > Do not discard the original packaging of your Phoenix Knee CPM. It provides required protection for your unit during shipping and must be used when returning your unit for service. Damages resulting from packaging unit in anything other than the required Phoenix container are the responsibility of the owner. Unapproved or badly damaged Phoenix containers will be replaced and billed accordingly.
- > Return Authorization Numbers are required. Contact Customer Support at 800.273.5233 with Serial Number, contact information and required repair description.
- > Ship your unit to our Technical Service Department at:
MCKELOR TECHNOLOGIES, LTD.
ATTN: (RA NUMBER)
6312 SEEDS ROAD
GROVE CITY, OH 43123

Phoenix Model 1850 Knee CPM Operator's Manual

Section 2 - Service & Maintenance

TABLE OF CONTENTS

	<u>PAGE</u>
Calibration Procedure	2-2
Pause Option Procedure	2-2
Motor Only Preventative Maintenance Procedure	3-2
Knee Potentiometer Assembly Replacement Procedure	4-2
Motor & Gearbox Replacement Procedure	5-2
On/Off Switch Replacement Procedure	6-2
Power Supply Replacement Procedure	7-2
Track Seal Replacement Procedure	8-2
Replacement Parts List	9-2
Quick Reference Guide	10-2

Phoenix Model 1850 Knee CPM

Calibration Procedure

- - -

Pause Option Procedure

Use this procedure when:

- * Replacing the circuit board
- * Replacing the knee potentiometer assembly

Tools required:

Protractor, Phillips Head Screwdriver, & 3/32 Allen Wrench

Procedure:

- * Remove control box cover
 - * Remove kneepot cover
 - * Power up unit and listen for one audible beep.
1. Locate the slide switch (SW1) on the main circuit board. Move the switch from 'RUN' position to the 'CAL' position.
 2. Using the up or down arrows on pendant, move the leg cradle to 0°.
 - Position a straight-edged tool (or item such as a ruler) on top right or top left side of leg cradle. Unit is at 0° when the tool is even or 'flat' on the cradle.
 3. Loosen the potentiometer clamps and gently turn the knee potentiometer. Observe the pendant display - the degree range indicator light (red dot) will appear in the Extension window. Continue to adjust the knee potentiometer until you have achieved a range reading of 2480 - 2500 . Stop adjusting and tighten the potentiometer clamps.
 4. Press and hold EXT button until beeper sounds indicating that the 0° position is set.
 5. Move cradle angle to 90° using the up arrow on pendant.
 - **Use a protractor to determine the 90° angle.**
 6. The degree range indicator light (red dot) will appear in the Flexion window indicating that the unit is within range.
 7. Press and hold the FLX button until the beeper sounds indicating that the 90° position is set.
 8. Slide switch on the main circuit board back to 'RUN' position.
 9. After calibration is complete, set the speed and range of motion to the desired setting and press the STOP/START button on pendant to lock in settings.

Flexion Pause add/remove procedure:

1. Turn the unit on and slide the switch on the circuit board from 'RUN' to 'CAL' position
2. If the unit is set for FLEXION PAUSE an 'F' will appear in the **extension** window.
3. To **remove** FLEXION PAUSE feature, press the "PAUSE" button.
4. To **add** FLEXION PAUSE feature, press the "PAUSE" button.
5. Slide the switch on the circuit board back to 'RUN' position.

Phoenix Knee CPM Series Motor Only - Preventative Maintenance Procedure

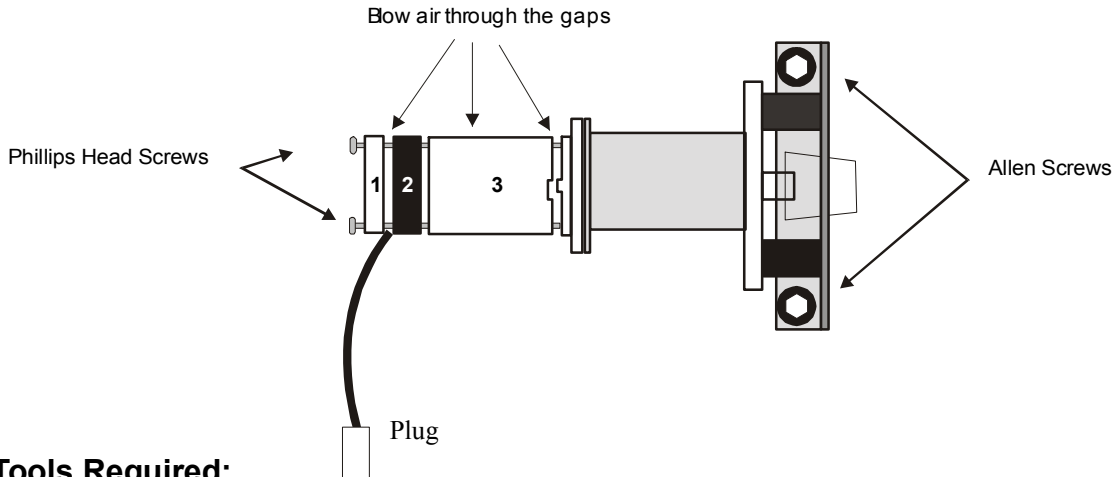

Tools Required:

- 9/64 Allen Wrench
- Phillips Head Screwdriver
- Compressed Air

Instructions:

1. Turn the power off to the unit.
2. Unplug the motor from the circuit board
3. Using the 9/64 Allen Wrench remove the allen screws that hold the Drive Assembly.
4. Remove the Drive Assembly.
5. Loosen the PhillipsHead Screws enough to create a gap between the 3 sections of the motor.

★ **Be careful not to remove the screws** ★

6. Blow enough air through the gaps (3) to clear the carbon build up.
7. Tighten the screws enough to secure the sections.
8. Return the Drive Assembly and test the unit.

Phoenix Knee CPM Series Knee Potentiometer Assembly Replacement Procedure

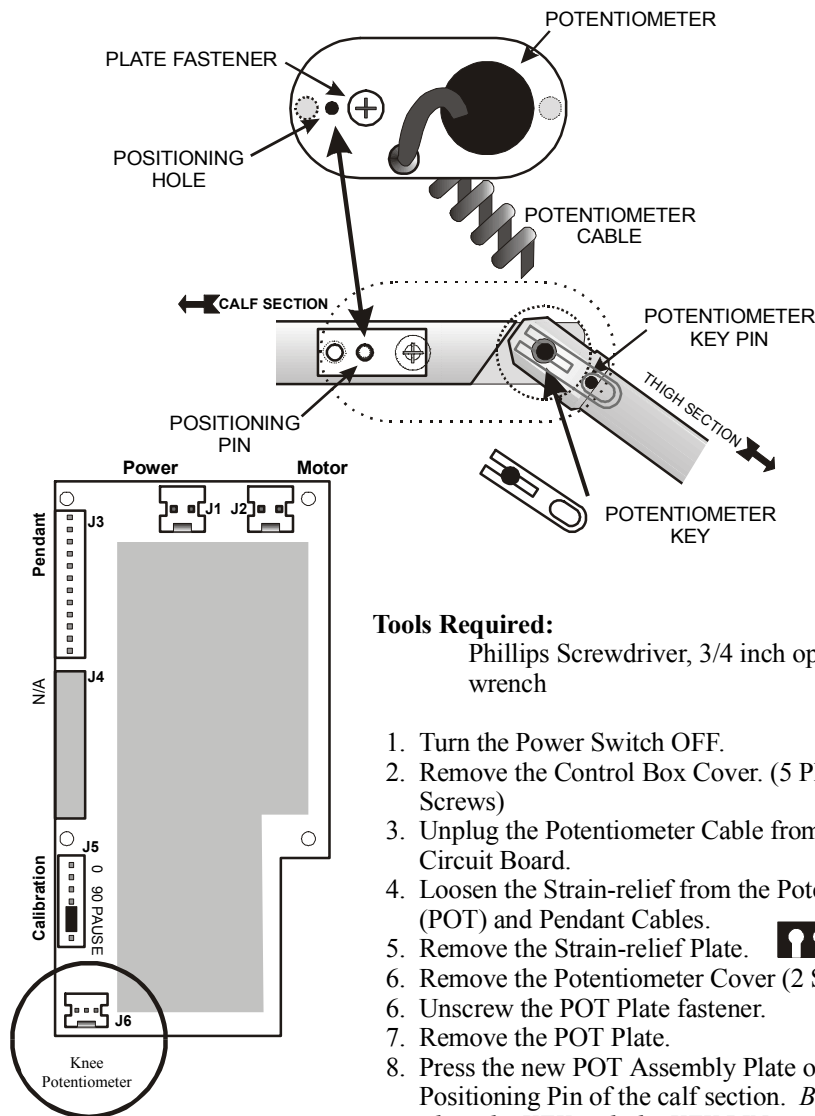

Tools Required:

Phillips Screwdriver, 3/4 inch open-end wrench

1. Turn the Power Switch OFF.
2. Remove the Control Box Cover. (5 Phillips Screws)
3. Unplug the Potentiometer Cable from J6 on the Circuit Board.
4. Loosen the Strain-relief from the Potentiometer (POT) and Pendant Cables.
5. Remove the Strain-relief Plate. 
6. Remove the Potentiometer Cover (2 Screws)
7. Remove the POT Plate.
8. Press the new POT Assembly Plate onto the Positioning Pin of the calf section. *Be careful to align the KEY with the KEY PIN on the Thigh Section.*
9. Secure the POT plate with the fastener.
10. Replace the POT and Pendant Cables. Secure the Strain-relief Plate.
11. Plug the POT Cable into J6 on the Circuit Board.
12. *Calibrate the Machine by following the Calibration instructions.*

Phoenix Knee CPM Series Motor & Gearbox Replacement Procedure

Tools required:

Phillips Head Screwdriver, Small Flat Head
Screwdriver, 9/64th Allen Wrench

1. Turn the Power Switch OFF.
2. Remove the Control Box Cover. (5 Phillips
Screws)
3. Unplug the Motor from the Circuit Board.
4. Remove the Motor and gearbox assembly using the Allen
Wrench to unscrew the two(2) screws from the motor
mounting bracket.
5. Unplug the gearbox coupling from the rubber coupler.
6. Remove the motor mount bracket by removing the (4)
Allen screws from the rubber bushings..
7. Attach the NEW motor and gearbox.
8. Plug the coupling into the rubber coupler.
9. Secure the motor mounting bracket with the two (2)
screws.
10. Plug in the motor to the Circuit Board.
11. Replace the top cover.

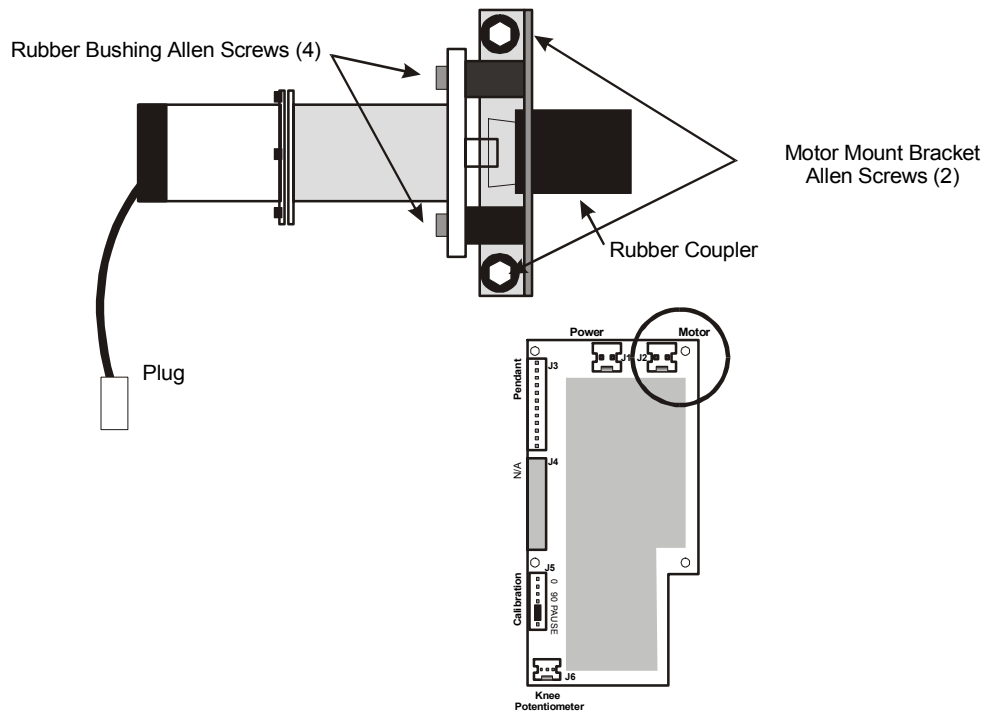

Phoenix Knee CPM Series On/Off Switch Replacement Procedure

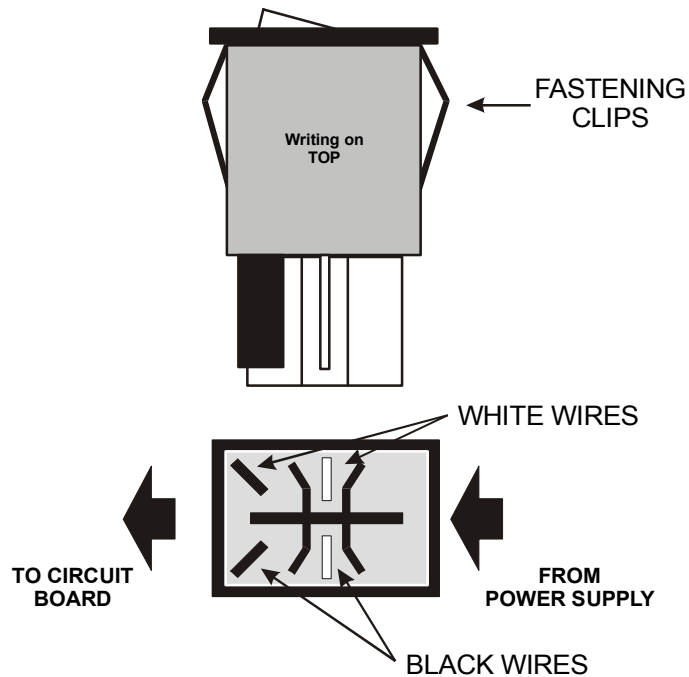

Tools Required:
Pliers

Caution: To avoid electric shock unplug the unit before beginning this procedure.

1. Turn the Power Switch OFF and unplug unit from wall outlet.
2. Remove the Control Box Cover. (5 Phillips Screws)
3. Unplug the the 2 white and 2 black wires from the back of the ON/OFF switch.
4. Use the pliers to squeeze the fastening clips and push the switch out.
5. Press the new ON/OFF switch into position.
6. Plug in the WHITE and BLACK wires as indicated above.(See illustration)
7. Replace the cover.

Phoenix Knee CPM Series

Power Supply Replacement Procedure

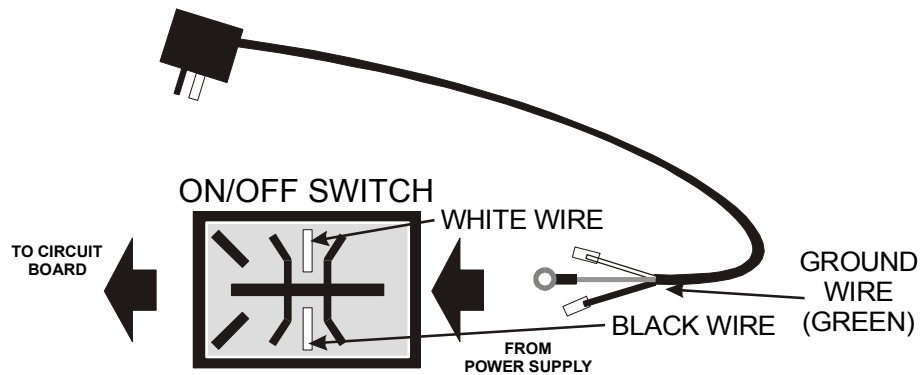

Tools Required:

Pliers, Phillips Head Screwdriver

Caution: To avoid electric shock unplug the unit before beginning this procedure.

1. Turn the Power Switch OFF and unplug the unit from wall outlet.
2. Remove the Control Box Cover. (5 Phillips Screws)
3. Unplug the white and black wires from the POWER SUPPLY side of the ON/OFF switch. (See illustration)
4. Disconnect the green ground wire
5. Using the pliers squeeze the sides of the strain-relief. Push the strain-relief out.
6. Remove the power supply cord.
7. Thread the new Power Supply through the opening.
8. Replace the strain relief.
9. Plug in the white and black wires as indicated above. (See illustration)
10. Attach the green ground wire.

Phoenix Knee CPM Series

Track Seal Replacement Procedure

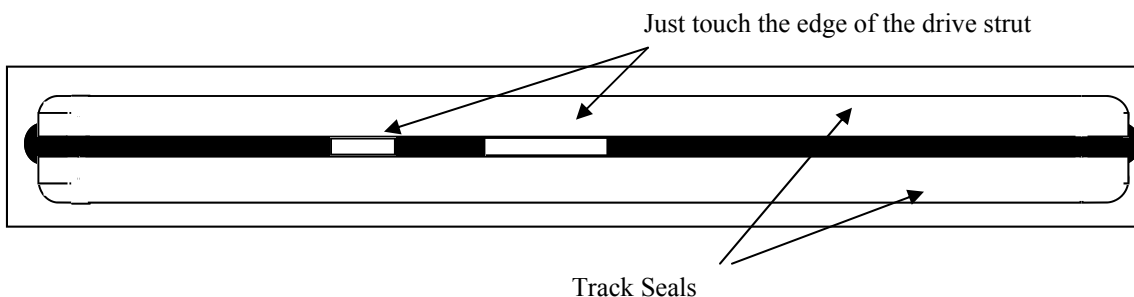

Equipment required:

1. Track Seal Kit (Part No. Skit1707A)
Includes: 4 Track Seals & 2 Packets of adhesive
2. Adhesive remover & Alcohol

Attaching the Track Seals:

1. Remove the old track seal.
2. Clean off any adhesive residue from the old track seal. *Surfaces must be cleaned thoroughly for the new track seal to adhere properly.* Clean with adhesive remover (Goo-Gone) and alcohol.
3. Attach the track seals to the edge of the track opening by sliding the open side of the new track seal along the edge of the opening.
4. Lift the top side of the new track seal and apply a bead of adhesive (a little goes a long way) along the full length of the entire strip.

Phoenix Knee CPM Model 1850

Replacement Parts List

SKIT1223	Phoenix Hardware/Fastners
SKIT1225	Pendant Start Stop Switch
SKIT1231	Pendant Velcro Strap
SKIT1420	Knee POT Assembly
SKIT1511A	Power Supply, Domestic
SKIT1600	Foot Assembly
SKIT1613	Knob Kit
SKIT1707A	Track Seals
SKIT1724	Hip Pivot
SKIT1727	Delron Spacer & Shoulder Bolt Kit
SKIT1734	Motor & Gear Box (Phoenix)
SKIT1801	Bed Tube Assembly
SKIT1804	Cable Velcro Straps (pkg/5)
SKIT1812	Skid Pad Kit
SKIT1823	Phoenix POT Cover Kit (Includes Hardware & Label)
SKIT1823A	Phoenix POT Covers (3) Only
SKIT1825	Phoenix ROM Label (Pkg of 10)
SKIT1834	Phoenix Shipping Carton (Complete)
SKIT1850	Pendant Assembly Complete (1850)
SKIT1906	Motor Only
SKIT3611	Velcro
1850	Pendant Enclosure (1850)
2103	Pendant Overlay (1850)
2104	Pendant Cable (1850)

MCKELOR Technical Service Department - 800.273.5233

www.mckelor.com

Phoenix Model 1850 Quick Reference Guide

Safety Guidelines

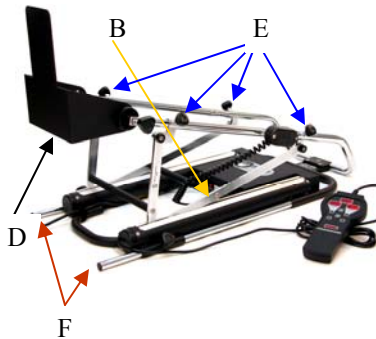

- A) Plug power supply securely into wall outlet & ensure all cords are out of the walk way
- B) To power on unit, on/off switch is located on the back of the control box
- C) Check that all softgood Velcro is securely fastened
- D) Foot assembly should be in upright position - Tighten foot adjustment knobs
- E) Tighten all adjustment knobs
- F) To prevent migration, extend bed stabilizer tubes and tighten knobs

Controller Overview

- A) To change settings, press and hold the function to be changed and the up or down arrow simultaneously. *NOTE: A 5 degree difference between flexion and extension is required for normal operation.*
- B) Depress the start/stop button to lock in the settings or changes
- C) To view patient compliance meter, simultaneously press the flexion and speed buttons. To clear, press the extension, flexion, speed and pause buttons simultaneously
- D) To activate lock-out feature, remove the plate located on the back of the pendant and slide the switch to the locked position. **Be sure to replace plate.** The display will read "LOC" should any attempt be made to alter the settings.



www.mckelor.com