

May 1994

**Operating and Service Manual**

*SCD™ Compression System  
Controller Model 5325*

*Serial Number* \_\_\_\_\_

**KENDALL**  
HEALTHCARE PRODUCTS COMPANY

A DIVISION OF THE KENDALL COMPANY  
15 HAMPSHIRE STREET ■ MANSFIELD, MA 02048

# Contents

	<i>Page</i>
<b><i>General Operating Instructions</i></b>	
Pre-Operation Check	2
Operation	2
Fault Conditions	4
Watchdog Circuit	6
Contraindications	6
Cautions	6
<b><i>Service and Maintenance</i></b>	
Warranty and Factory Service	7
Filter Maintenance	8
Ventilation	8
Fuses	9
Electrical Safety	9
Cleaning	9
Electronics Description	9
Pneumatics Description	10
Port Identity	10
Start-up Routine	10
<b><i>Calibration/Test Methods</i></b>	
Calibration Procedure	11
Valve Function Test	13
<b><i>Disassembly/Reassembly</i></b>	
Instruction Card Replacement	15
Case Removal	15
Circuit Board Removal	16
Circuit Board Installation	16
Compressor	16
Solenoid Valves	17
Case Reassembly	18
<b><i>Drawings &amp; Specifications</i></b>	<b><i>Appendix</i></b>

This product is a component of Kendall's SCD System that is covered by U.S. Patent No. 4,253,449. The use of non-Kendall components in place of and/or in combination with this Kendall component may constitute infringement of Kendall U.S. Patent No. 4,253,449. Kendall expressly states that no implied license with respect to use of non-Kendall components is granted by the sale or lease of this component.

## General Operating Instructions

The SCD Compression System is designed to apply thigh-length sequential gradient compression to the lower limbs to prevent deep vein thrombosis in patients at risk.

### Pre-Operation Check

Before using the SCD System on the patient, verify that:

- \* The Tubing is properly connected to the Controller and the Sleeves. Both Sleeves must be connected. If the System can only be used on one leg, (e.g., amputee), connect the second sleeve but leave it packaged in its plastic bag.
- \* There are no kinks or sharp bends in the Tubing.
- \* The back and bottom of the Controller are unobstructed for free air flow.
- \* The Controller power cord is plugged into a grounded AC receptacle of the correct voltage.
- \* No flammable anesthetic gases are present.

### Operation

Turn the power switch on. The Controller performs a self-diagnosis and lamp check upon start-up. The LED segments light, starting at the top of the display panel. They light in sequence to the bottom. At the end of this test (approximately 2 seconds), there is a 2 to 6 second pause in which the flow control valve is set within the required range. The Controller then begins normal operation with ankle inflation.

*NOTE: The Controller "wakes up" with the Sleeve Cooling off and the Audible Alarm on. To change either, press the appropriate membrane switch while the machine is operating. An adjacent LED will indicate when the option is on.*

In the case of a SYSTEM HIGH [SH] or DIAGNOSTIC [D(n)] fault condition, the alarm will sound immediately if the Audible Alarm is enabled or it will sound after a one minute delay if the Audible alarm is disabled. The FAULT LED will light, the appropriate fault code will be displayed and the Controller will shut down immediately in either case.

### Cycle Monitor

The SCD 5325 Controller has a Cycle Monitor which continuously displays the status of the Controller's compression sequence. The Monitor consists of four back lit panels which, when lighted, read: ANKLE, CALF, THIGH and VENT. These represent the four major divisions of one complete cycle. During operation, the ANKLE, CALF, THIGH and VENT lights will light, one at a time, to indicate each of the major cycle divisions in turn.

Also featured is a ten-segment bar graph. Each of the ten segments of the bar graph represents ten percent of a major cycle division and will light in sequence to indicate how much of a major cycle division is complete. For example, the VENT (decompression) portion of the cycle is 60 seconds long. Since there are 10 bar graph segments, each representing 10% of the cycle, a new segment will light every 6 seconds during decompression.

## **Automatic Pressure Adjustment**

The SCD 5325 Controller features microprocessor controlled automatic pressure adjustment that not only sets the pressure automatically, but maintains the set pressure no matter how the patient moves or changes position.

DEFAULT

After the start-up sequence, the Controller will set itself at 45mmHg and display that as the *set pressure*. The SETTING LED will light indicating the Controller is in the process of adjusting the *actual pressure* to match the *set pressure*. Within four cycles, the SETTING LED will turn off and the RUN LED will come on, indicating that the *actual pressure* is within 2mmHg of the *set pressure*.

If a pressure other than 45mmHg is desired, the set pressure may be changed by pressing either the Up or Down arrow buttons located to the right of the display. Each time the UP or DOWN button is pressed, the set pressure will be raised or lowered 1mmHg respectively.

Pressing and holding one of the buttons for at least two seconds will cause the set pressure to scroll rapidly. Whenever the set pressure is changed, the SETTING LED will come on while the Controller is matching the actual pressure to the set pressure. When the actual pressure is within 2mmHg, the RUN LED will light.

*NOTE: Even after the RUN LED is on, the Controller will continue to make small adjustments in order to more perfectly match the set pressure.*

## **Pressure Monitoring**

The LED display that is used to show the set pressure can also be used to display the actual pressure. Press the center of the black bar area to the left of the display for two seconds. This will cause the display to change to Pressure Monitor Mode. The Controller will stay in this mode throughout the current compression portion of the cycle (or the next compression cycle if the button is pressed during the VENT portion of the cycle). The last reading of the compression portion of the cycle will be displayed for thirty seconds. At the beginning of the next inflation cycle the display will revert to showing the set pressure.

When the Controller is in the pressure Monitor Mode, a decimal point will flash on either side of the seven segment display, indicating that the actual pressure is being displayed.

## Fault Conditions

4

### Fault Messages: <sup>(1)</sup>

Code	Fault Type	Description
SL	System Low	<p>There is less than 5mmHg pressure at the end of the first thigh cycle or at the end of two consecutive cycles thereafter.</p> <p><i>Potential Causes</i></p> <ul style="list-style-type: none"><li>• Tubing is not properly connected.</li><li>• There is a leak inside the Controller.</li></ul> <p><i>Corrective Actions</i></p> <ul style="list-style-type: none"><li>• Ensure proper Tubing connections.</li><li>• Turn the Controller off and restart. If the Controller displays the same fault, the unit requires servicing.</li></ul>
LO	Low	<p>The Controller is unable to bring the pressure up to within 2mmHg of the set pressure during five consecutive cycles. The pressure in the Sleeves is consistently below the set pressure. The Controller will shut off and display this code.</p> <p><i>Potential Causes</i></p> <ul style="list-style-type: none"><li>• Tubing is not properly connected.</li><li>• Sleeves are too loose.</li><li>• Flow control valve is stuck.</li></ul> <p><i>Corrective Actions</i></p> <ul style="list-style-type: none"><li>• Ensure proper Tubing connections.</li><li>• Apply Sleeves so that only two fingers fit snugly between each Sleeve and the patient's leg.</li><li>• Turn the Controller off and restart. If the Controller displays the same fault, the unit requires servicing.</li></ul>
SH	System High	<p>Pressure has exceeded 90mmHg after 1.2 seconds of thigh cycle:</p> <ul style="list-style-type: none"><li>• On first cycle, Controller will switch to vent mode and adjust flow control appropriately.</li><li>• On subsequent cycles, Controller will switch to the fault mode and display this code.</li></ul>

(1) When the microprocessor detects a fault condition, it interrupts the normal operation of the controller, closes all solenoid valves, displays a fault code, and sounds an audible alarm. (The alarm may be disabled by pressing the Audible button after the Controller is running. When the Controller is in the FAULT mode, it can be reset by turning the power off and then back on.

<i>Code</i>	<i>Fault Type</i>	<i>Description</i>
SH	System High (cont.)	<p><i>Potential Causes</i></p> <ul style="list-style-type: none"> <li>• Tubing is kinked.</li> <li>• Sleeves are too tight.</li> <li>• The set pressure has been changed too rapidly from a very low pressure to a very high pressure.</li> </ul> <p><i>Corrective Actions</i></p> <ul style="list-style-type: none"> <li>• Straighten out kinked Tubing.</li> <li>• Apply the Sleeves so that two fingers can fit snugly between each Sleeve and the patient's leg.</li> <li>• Turn the Controller off and restart. If the Controller displays the same fault, the unit requires servicing.</li> </ul>
HI	High	<p>The Controller is unable to bring the pressure down to within 2mmHg of the set pressure during five consecutive cycles. The pressure in the Sleeves is consistently above the set pressure. The Controller will shut off and display this code.</p> <p><i>Potential Causes</i></p> <ul style="list-style-type: none"> <li>• Sleeves are too tight.</li> <li>• Flow control valve is stuck.</li> </ul> <p><i>Corrective Actions</i></p> <ul style="list-style-type: none"> <li>• Apply the Sleeves so that two fingers can fit snugly between each Sleeve and the patient's leg.</li> <li>• Turn the Controller off and restart. If the Controller displays the same fault, the unit requires servicing.</li> </ul>
d1	Internal Diagnostic One	<p>If the pressure exceeds 6mmHg after 6 seconds of the vent cycle, or if a power transducer failed shorted, causing the solenoid valve to stay open, the microprocessor would detect these conditions, shut the Controller off and display this code.</p> <p>The Controller should be returned to the manufacturer for repair.</p>
d2	Internal Diagnostic Two	<p>Upon start-up, the microprocessor performs diagnostic tests. If the Controller fails to pass all of these tests, it will not start and this fault code will be displayed.</p> <p>The Controller should be returned to the manufacturer for repair.</p>

<b>Code</b>	<b>Fault Type</b>	<b>Description</b>
d3	Internal Diagnostic Three	This fault is detected only during special test conditions and should not occur during normal operation.  The Controller should be returned to the manufacturer for repair.
d4	Internal Diagnostic Four	This fault is detected only during special test conditions and should not occur during normal operation.  The Controller should be returned to the manufacturer for repair.

### **Watchdog Circuit**

If the Microprocessor cannot continue normal software execution, the watchdog will trip. This causes the Controller to go into reset and restart normal operation.

If the cause of the disruption is still present, the unit will continue to attempt to reset, which will cause the alarm to beep at a 1.0 Hz rate.

If the cause of the disruption was transient, such as a high energy RF pulse, the Controller will restart. This will cause all of the settings to revert to their default states, i.e., the COOLING will be OFF, the AUDIBLE ALARM will be ON, and the pressure will be set at 45mmHg.

## **Contraindications**

The SCD Compression System may not be recommended for patients with the following:

1. Any local leg condition in which sleeves would interfere such as:
  - a. Dermatitis
  - b. Vein ligation (immediate postoperative)
  - c. Gangrene
  - d. Recent skin graft
2. Severe arteriosclerosis or other ischemic vascular disease.
3. Massive edema of legs or pulmonary edema from congestive heart failure.
4. Extreme deformity of leg.
5. Suspected existing deep venous thrombosis.

## **Cautions**

1. When this device is used in the Operating Room, keep Sleeve Cooling OFF to maintain air quiescence.
2. Federal law restricts this device to sale by or on the order of a physician.
3. Explosion Hazard. Do not use in the presence of flammable anesthetics.



## **Service and Maintenance**

### *Introduction*

The service technician should be familiar with operator's portion of this manual and the operating principles of the SCD 5325 Controller. The fault codes displayed by the Controller are useful in diagnosing service problems. If a Controller is to be returned for service, a description of any fault code displayed should accompany the unit.

This manual describes service procedures to the board level. If a component failure on a circuit board is suspected, the unit should be returned for service. It is recommended that the instrument be returned with the circuit board in place, as removal of the board(s) involves additional risk of mechanical damage and damage from electrostatic discharge.

### *Warranty and Factory Service*

The Kendall Healthcare Products Company warrants that your SCD 5325 Controller is free from defective material and workmanship. Our obligation under this warranty is limited to the repair of instruments returned to the service address indicated below, transportation charges prepaid, within one year of delivery to the original purchaser. Specifically, we agree to service and or adjust any instrument as required if returned for that purpose, and to replace and repair any part which, upon our examination, is proven to have been defective. This warranty does not apply to the Tubing Assembly or the individual disposable leg Sleeves, or to equipment damaged through shipping, tampering, negligence, or misuse, including liquid immersion, autoclaving, or ETO sterilization.

**THIS LIMITED WARRANTY DOES NOT COVER, AND IS INTENDED TO EXCLUDE, ANY AND ALL LIABILITY ON THE PART OF THE COMPANY, WHETHER UNDER THIS LIMITED WARRANTY OR ANY WARRANTY IMPLIED BY LAW, FOR ANY INDIRECT OR CONSEQUENTIAL DAMAGES FOR BREACH HEREOF OR THEREOF EXCEPT AS EXPRESSLY PROVIDED ABOVE IN THE LIMITED WARRANTY, THE COMPANY HEREBY NEGATES AND DISCLAIMS ALL EXPRESS AND IMPLIED WARRANTIES, INCLUDING THE WARRANTIES OR MERCHANTABILITY AND FITNESS FOR A PARTICULAR PURPOSE.**

Some states do not allow the exclusion or limitation of incidental or consequential damages, so the foregoing limitation or exclusion regarding damages may not apply. Also, this Limited Warranty gives you specific legal rights, and you may also have other rights which vary from state to state.

**THIS SERVICE MANUAL IS INTENDED FOR USE AS A GUIDE TO TECHNICALLY QUALIFIED PERSONNEL WHEN EVALUATING INSTRUMENT MALFUNCTIONS. IT IS NOT TO BE CONSTRUED AS AUTHORIZATION TO PERFORM WARRANTY REPAIRS. UNAUTHORIZED SERVICE WILL VOID THE WARRANTY.**

**CALIBRATION USING THE PROCEDURES OUTLINED IN THIS MANUAL VOIDS THE FACTORY CALIBRATION CERTIFICATION.**

Instruments requiring warranty repairs must be shipped, prepaid and insured, to the Service Center. The Kendall Healthcare Products Company maintains service facilities with the capability to promptly repair the SCD 5325 Controller. In the events of any service maintenance problem, contact the Service Manager. The toll-free number is (800) 765-4324. If the instrument is to be returned for service, please call the above number to obtain a return material authorization number and send it prepaid and insured, in the original carton to:

Service Manager  
Electronic Assembly Corporation  
585 Enterprise Drive, Bldg. #4  
Neenah, WI 54956

### ***Filter Maintenance***

There are two filters used in the SCD 5325 Controller – an external filter and a compressor filter. Both filters can be accessed by removing the rear cover of the Controller. To do this, remove the two screws at the back of the Controller.

It is very important that the external air filter be cleaned frequently to insure continued trouble-free operation. The Controller should never be run without the filter in place. To clean the external filter, lift it from the Controller and brush loose dust and lint from the surface. Wash the filter in a mild detergent solution, dry thoroughly, and reinstall.

Removal of the rear cover also exposes the compressor filter. This filter should be cleaned monthly or more frequently if the external filter shows frequent clogging. Remove the screw in the center of this filter housing. The filter is mounted on fingers on the inside of the housing. Remove the filter element from the housing and wash in a mild detergent solution, rinse and dry thoroughly. *Do not use oil on the filter.* Inspect the filter for lint before reassembly. Lint suppression is essential to prevent the malfunction of the pump and solenoid valves. Reassemble carefully making sure that the housing is properly seated on the pump casting. Replace the rear cover and retaining screws.

### ***Ventilation***

Obstruction of the back and bottom vents should be avoided. Free flow of air is necessary to prevent overheating and premature component failure.

5

## **Fuses**

Blown fuses should be replaced with ones of the proper rating and type. This instrument uses two 3AG slow-blow fuses:

1. 1.0-ampere
2. 0.4-ampere

If a fuse blows a second time, it should be presumed that the instrument is defective and requires further service.

**CAUTION:** *Unplug the Controller before removing the fuses.*

## **Electrical Safety**

Periodic inspection should include a resistance check from the power plug grounding prong to the metal chassis inside the instrument. This resistance should not exceed 0.1 ohm.

If ground resistance exceeds this value or the insulation integrity of the unit has been compromised through mechanical damage, the Controller should be returned to the service center for testing and repair.

**CAUTION:** *Be sure the Controller is disconnected from the power source before removing the top cover. A potential SHOCK HAZARD exists when the top cover is removed even with the unit turned off.*

## **Cleaning**

The Controller case can be cleaned with a soft cloth dampened with water. If necessary, a mild disinfectant and/or detergent can be used, but excess fluid should be avoided. The Controller should be wiped with a clean, dry cloth afterward. Do not immerse in water.

The SCD 5325 Controller cannot be effectively sterilized by liquid immersion, autoclaving, or ETO sterilization. To do so will irreparably damage the Controller.

## **Electrical/Electronics Description**

The electronics of the instrument are located on two PC boards that can be found back to back, beneath the membrane switch panel in the top case cover. There is no high voltage on the PCB's. The upper board is the display board and contains the LED's and associated electronics which display information about the state of the Controller during normal operation, as well as in the fault mode or the various calibration and diagnostic modes.

The lower board is the control board. It contains voltage regulation circuits, analog conditioning circuits, the pressure transducer, the microprocessor and input circuits to read the switches. The board also contains output drivers to turn on/off the solenoid valves, control the flow control valve and sound the alarm. A pressure transducer provides the microprocessor information on the operating pressure of the system, which it uses to modify the flow of air through the flow control valve.

Operator input is provided through the membrane switch panel. Component failure will result in de-energizing the solenoid valves and the closing of the flow control valve. This will release pressure from the attached leg sleeves.

## ***Pneumatics Description***

The compressor, driven by a low noise linear motor, runs continuously while the Controller is on. Air can be directed from the compressor to the sleeve cooling chambers during the 60 second vent phase by pressing the Sleeve Cooling button on the membrane switch panel. This causes the solenoid valve SV4 to be energized during the VENT phase.

Air flow to the solenoid valve manifold assembly is controlled by the flow control valve which is driven by the linear stepper motor in response to step patterns from the microprocessor. From the manifold assembly, it is gated to the sleeve chambers during the 11 second compression phase by energizing solenoid valves SV1, SV2, and SV3 in sequence. At the end of this period, all three solenoid valves are de-energized simultaneously which disconnects the compressor from the sleeves and allows the valves to vent to atmosphere. The pressure transducer monitors the pressure in the ankle portion of the circuit and provides data input to the microprocessor for closed loop control.

## ***Port Identity***

The Tubing Set connecting the Sleeves to the Controller is attached to the fitting on the front of the Controller in the lower left hand corner. Inside this fitting are four ports which are, from left to right: ANKLE, COOLING, CALF, and THIGH. (See Figure #4.)

## ***Controller Start-Up Routine***

**PHASE I:** When the Controller is turned on, it commences a series of tests lasting six seconds: <sup>(2)</sup>

1. All LEDs light and the beeper sounds for 0.5 seconds.
2. The FAULT and the two Seven Segment LEDs light (Displaying "88"). Then the FAULT LED extinguishes.
3. The Cycle Monitor LEDs light and extinguish.
4. The SETTING, RUN, COOLING and AUDIBLE ALARM LEDs light. The Beeper sounds briefly and the SETTING, RUN and COOLING LEDs extinguish.

**PHASE II:** The set pressure is displayed and the SETTING LED flashes. During this phase, the flow control valve is adjusted to a predetermined start position. This process will take from 2 to 6 seconds, depending upon the position of the valve when the Controller was last turned off.

**PHASE III:** The normal operating cycle begins with ankle inflation. At this time the AUDIBLE ALARM indicator relights. <sup>(3)</sup>

(2) Detection of inoperative LED's and the Beeper function is the user's responsibility. The start-up routine also tests microprocessor function and system memory. If a fault condition is detected, either a [D(n)] fault code will be displayed or the unit will repeatedly go into reset which will result in a long beep at a 1 Hz rate.

(3) At the end of the first thigh cycle, a short beep indicates that the actual pressure was more than 13 mmHg above the set pressure. (Typically occurs with smaller sleeves and the Controller changes its adjustment routine to one that is appropriate for smaller sleeves.)

## Calibration/Test Methods

See Disassembly/Reassembly procedure before testing.

### Introduction

The SCD 5325 Controller has several special calibrating and test modes that can be used to verify the pressure transducer calibration and proper function of the flow control valve and its drive circuits. They can also verify the microprocessor, solenoid valve and pneumatic functionality.

1. Factory calibration certification is void if the unit is opened.
2. Unit should only be opened by persons trained in \*ESD\* methods and equipment.

### Calibration Procedure

Equipment Required: A regulated air source with a constant output pressure set at 45.0mmHg  $\pm$  0.2mmHg and a voltmeter.

*NOTE: The pressure transducer used in the SCD 5325 Controller is a state-of-the-art, highly precise, and nearly drift-free device. It is not expected to require recalibration for several years of continuous use.*

1. Unplug the Controller.
2. Remove the rear filter cover and external filter. (See FILTER CLEANING.)
3. Turn the Controller over and remove the four screws located around the shelf bottom.
4. Carefully turn the Controller right side up and rotate it until the front is facing you.
5. Gently lift the top cover straight up until it just clears the internal components. Tilt it to the left until it can be rested on its left side. (Make sure the various electrical and pneumatic connections between the control PCB and the rest of the unit are not dislodged.)
6. Carefully disconnect the Luer Lock connector in the middle of the Tubing that is attached to the Pressure Transducer. **Fig 24**
7. Connect the voltmeter to Test Point 1, GROUND, and Test Point 3, AMPLIFIER OUTPUT. (Expected output 0 to + 2.5 VDC).
8. Plug the unit into a wall outlet. **CAUTION: ELECTRICAL SHOCK HAZARD.** Do not touch the electrical components on the chassis. The PCBs are not at line voltage.
9. Place the Controller in the calibration mode by pressing the center of the black bar area to the left of the display while turning on the Controller. The Controller will cycle from ANKLE to CALF to THIGH to VENT every five seconds.

10. With no air applied, the display should show 00mmHg.
  - On control boards with one potentiometer the voltmeter should read less than 0.019 VDC maximum.
  - On control boards with two potentiometers – adjust zero, R14, for  $0.000 \pm 0.005$  VDC if necessary.
11. Using a mating Luer fitting, connect the calibrated air pressure source to the Pressure Transducer.
12. With  $45 \pm 0.2$ mmHg applied, the display should show 45mmHg
  - On control boards with one potentiometer – voltmeter should read  $1.085 \pm 0.005$  VDC – adjust R14 if necessary. CCW ↓
  - On control boards with two potentiometers – voltmeter should read  $1.125 \pm 0.005$  VDC – adjust GAIN, R19, if necessary.
13. Reconnect the Luer Lock by rotating both connectors one-quarter turn counterclockwise. Then rotate clockwise to lock. Particular care should be taken to avoid stressing the fitting on the pressure transducer.
14. Carefully replace the top cover and turn the Controller over.
15. Replace the four screws. (Do not over-tighten.) Replace the external filter and the rear filter cover.

**WARNING: Do not attempt to repair or replace broken tubing connectors as hazardous inflation of the sleeves may occur.**

## **Valve Function Test**

The following describes a Valve Function Test which can be used to exercise the flow control valve under the control of the microprocessor. This test is not part of the normal testing and maintenance routine, but can be used in the event of disassembly to verify:

- The correct wiring and connection of the solenoid valves.
- The correct wiring and connection of the flow control valve.
- The correct orientation and connection of the pneumatic circuit.
- There are no leaks or blockage of the pneumatic circuit.
- The solenoid and flow control valves are operating correctly.

## **Equipment Required**

- Four Dwyer Flow Rate Gauges #RMC-101 (Range of 5 to 50 LPM). Other flow meters will work, but will require some experimentation to determine the optimum range. (The output is influenced by the back pressure of the flow meters.) Dwyer's phone number is 219-879-8000.
- One Harness Coupling – Kendall part number HC-78.
- Four lengths of flexible tubing – 3/16" ID. x 24" Vinyl or Rubber.

*Assemble as shown in Figure 1 in the Appendix.*

## **Procedure**

1. Attach the Flow Meter Assembly to the Tubing fitting on the front of the SCD Controller.
2. Press and hold the Up and Down arrow buttons while turning on the Controller. This places the Controller in the Stand-by Mode. The Display will show "Sb".
3. Press the Audible Alarm button.
  - The beeper will sound seven times.
  - The ankle solenoid valve will open and the flow control valve will begin to open. *This will be indicated by the sequential lighting of the segments of the ten segment display that is part of the Cycle Monitor. The number of segments lit is an approximate indication of the position of the valve. For example, five segments lit indicates the valve is half open. As the valve opens, the ankle flow meter will show a corresponding smooth rise.*
  - The beeper will sound and the flow control valve will pause for five seconds when halfway open.
  - The flow control valve will continue to open. When it is fully open, the beeper will sound and the valve will pause for five seconds.
  - The flow control valve will close to the halfway point, the beeper will sound and the valve will pause for five seconds.
  - The flow control valve will close all the way. The ankle solenoid valve will close and the calf solenoid valve will open.

- The sequence will be repeated for the calf, thigh and vent circuits except that the flow control valve will not pause at the halfway point. *A corresponding smooth rise should be seen on the appropriate flow meters for the calf and thigh circuits. The vent circuit does not pass through the flow control valve, so the associated meter will snap to a higher value immediately and stay there during its portion of the test.*
- When the vent circuit has completed its cycle, the Controller will return to the Stand-by Mode.

## **Alternate Valve Function Test**

### *Procedure*

1. Press and hold the UP and DOWN arrow buttons while turning on the Controller. This places the Controller in the Stand-by Mode. The display will show "Sb".
2. Press the Audible Alarm button.
  - The beeper will sound seven times.
  - The Controller will sequence through the following cycle: Ankle, Calf, Thigh, and Cooling Vent.
3. Gently hold a finger near each air outlet port on the front of the SCD to verify air flow is present for each cycle at the correct port. The order of the ports from left to right are Ankle, Cooling Vent, Calf, and Thigh. See Appendix Figure 2. The flow control valve will open as in previous Section 3, there should be a corresponding smooth and gradual increase then decrease in flow sensed for the Ankle, Calf, and Thigh circuits. The Vent will start and stop abruptly.
4. The Controller will return to the Stand-by Mode after one complete cycle.



## Disassembly/Reassembly

### *Instruction Card Replacement*

1. Remove the two rear filter cover screws and lift off the filter cover.
2. Pull the cord from the notch located between the case top and the handle.
3. Insert the new cord through the notch from the handle side and apply a metal crimp or tie a knot in the end of the cord.
4. Replace the filter cover and reinstall the two filter cover screws.

### *Case Removal*

*CAUTION: SHOCK HAZARD. Disconnect line cord from the power supply.*

*CAUTION: Disassembly of the case and particularly the disconnection of pneumatic and/or electronic components can disrupt the function and calibration of the instrument. It is strongly recommended that the Calibration Check and Valve Function Test be performed upon reassembly.*

*ESD WARNING: Unit should only be opened by person trained in ESD methods and equipment.*

Remove the case components in the following sequence:  
(See Figure 3 located in the Appendix.)

1. Remove the rear filter cover.

To remove the filter cover, remove the two screws located at the rear of the Controller, and lift off.

2. Remove the external filter.
3. Remove top cover.

To remove the top cover, turn the Controller upside down and remove the four screws located at the four corners of the raised shelf.

Hold the cover to the base and turn the Controller right side up. With the Controller facing you, lift the cover and rotate it to your left 90 degrees and lay it on its side.

Note the location and orientation of the connectors from the base components on the control PCB. Remove the connectors by gently pulling straight out.

Very gently disconnect the Leur Lok that connects the pneumatic circuit to the pressure transducer.

## ***Circuit Board Removal***

The control and display PC boards are located on the under side of the case top, beneath the control panel. The boards are stacked with the control board being the outer board when the case top is viewed from the bottom.

*CAUTION: Use a ground strap when handling any electronic components.*

1. Note the location and orientation of all the pneumatic and electrical connections to the chassis.
2. Disconnect all the pneumatic and electronic leads to the chassis.
3. Remove the four mounting screws located at the four corners of the control board and gently separate the boards until the connector between the two boards is free.
4. Remove the mounting nut/spacers holding the display board and lift the display board out.

*CAUTION: It is not recommended that components on the PC boards be removed or replaced. If a circuit board is suspected of being faulty, the unit can be returned for repair by calling the toll-free service number (800) 765-4324.*

## ***Circuit Board Installation***

*CAUTION: Use a ground strap when handling any electronic components.*

1. Carefully align the display board with the mounting screws.
2. Replace the four mounting nut/spacers to secure the display board.
3. Align the mating connectors on the display and control boards. Gently press them together.
4. Replace the four mounting screws to secure the control board.

## ***Compressor***

The Compressor is driven by a linear motor integral to the unit. Air is pumped by a spring loaded piston oscillating in a 60 Hertz magnetic field. With the outlet port open and line voltage at 115 volts, the compressor will draw approximately 1 ampere rms. If the outlet port is closed, the current will drop to approximately 0.75 amperes rms.

The field coil is energized from the power line through a rectifying diode. If an ohmmeter is used to test field coil continuity, it must be polarized to obtain forward conduction of the diode. Further, the voltage applied in a continuity test must be adequate to produce forward conduction. The Diode Test Function of digital multimeters can be used for this test. Some ohmmeters are not suitable.

- If the diode is shortened, the Compressor will not function; however, the current draw will be approximately normal.
- The diode is located inside the case and its replacement would require disassembly of the Compressor. *This should not be attempted.* Special jigs and fixtures are required to insure proper alignment during reassembly.

- If the diode is shorted, it is possible to connect a second diode in series, but located external to the compressor. *Such a repair should be attempted only by an experienced technician and in a configuration that does not compromise electrical safety.* The diode polarity does not affect compressor function.
- The diode rating should be 3 amperes and at least 800 volts PIV>

*NOTE: The Compressor used in the instrument is not a user serviceable component. Special jigs and fixtures are required to insure proper alignment during reassembly. Do not disassemble.*

### **Solenoid Valves**

- The solenoid valve that connects the pump to the Sleeve Cooling Port is a 2-way, normally closed type. When energized, it passes air to the port; when de-energized, flow is blocked.
- The solenoid valves connecting air flow from the flow control valve to the ANKLE, CALF, and THIGH ports are arranged in a block and are of the 3-way, normally closed type. When energized, these valves pass air to their respective Sleeve ports. When de-energized, pump air is blocked and air pressure in the Sleeves is released through the port on the top of that particular valve.
- The coils on all four valves are removable by removing the nut at the top of the valve.
- For information on coil resistance contact Electronic Assembly Corporation at 800-765-4324.
- Any debris in the air lines could cause mechanical malfunction of the solenoid valves. If this is suspected, the valve tubing should be disconnected and the valve flushed with filtered compressed air through the port while energizing the valves respectively from a 24-volt supply. Double filtration of incoming air guards against debris entering the compressor. If debris is present, it may indicate:
  - a. Failure to clean the filters when needed.
  - b. Physical breakdown of some component of the pneumatic circuit, for example, degradation of a section of tubing.

Low voltage from the 24-volt supply can also cause solenoid valve malfunction. Normal solenoid voltage requirement is 24 to 32 VDC.

### ***Case Reassembly***

1. Place the case base, with the complete chassis installed, on the bench in front of you with the front of the Controller towards you.
2. Place the case top on its left side to the left of the case base. The front of the case top should be toward you with the under portion of the case top towards the case base.
  - Reconnect all of the electrical connection in the proper location and orientation of the leads from the chassis components. Replace the connectors by gently pushing straight in.
  - Reconnect the Luer Lock by rotating both connectors one-quarter turn counterclockwise. Then rotate clockwise to lock. Particular care should be taken to avoid stressing the fitting on the pressure transducer.
3. Lift the case top and place it over the case base. Carefully align the two halves.
  - Turn the closed Controller over and reinstall the four screws.
  - Turn the unit right side up and perform the Valve Function Test and Calibration Check Procedure.

# SCD™ CONTROLLER

## Specifications

**Model #:** 5325

**UL Listing:** Built to UL 544 Standard – Listing KFBQ File #E116754

**Compression Type:** Sequential, Gradient Pressure

**Compression Cycle:** 11 Seconds Compression, 60 Seconds Decompression

**Preset Pressure:** 45mmHg

**Recommended Pressure Range:** 35mmHg – 55mmHg

**Audible/Visual Alarms:** Low Pressure, High Pressure, Internal Electronics  
Malfunction

**Sleeve Cooling Function:** Yes

**Cycle Monitor:** Yes

**Power Cord:** Hospital Grade Plug

**Controller Height:** 6-1/2"

**Controller Width:** 8-5/8"

**Controller Depth:** 13"

**Weight:** 14.3 lbs.

**Power Requirements:** 115 VAC, 114 VA, 60Hz

**Shipping Unit:** Each

**Shipping Case Dimensions:** Height, 11"; Width, 10"; Depth, 15-1/2"

**Shipping Weight:** 18 lbs.

**Tubing Assembly:** Included

**Operating Instructions Card:** Attached to unit

**Operating & Service Manual:** Included

# Parts Listing

Sleeves and Tubing Assemblies can only be purchased directly from Kendall Customer Service (1-800-962-9888).

To order repair parts listed here, call Electronic Assembly Corporation at 1-800-765-4324.

<u>Description</u>	<u>Part Number</u>
Air Filter Card	KL7065
Compressor Filter	MDOLP12174
Compressor	MDOAC0502
Compressor Foot	MDOLA1622D
Cabinet Kit Complete	KL8084
Cabinet, Handle	KL8085
Cabinet, Back Cover	KL8086
Cabinet, Top	KL8087
Cabinet, Base	KL8088
Fan, 60mm, 24V	KL7063
Fuse .4 Amp, 3AG Sloblo	LF313.400
Fuse 1 Amp, 3AG Sloblo	LF313001
Fuseholder	LF345611
Harness Coupling	HC-78
Insert Nipple	KL5822
Insert Tubing	KL5820
Label, "Explosion Hazard"	KL7073
Label, Fuse	KL7075
Label, "Maintain Ground"	KL5810
Membrane Switch	KL7064
Operating Instructions, Card w/Tether	KL7049
Power Cord, Molded Plug, 13 ft	KL7060
Rubber Case Foot w/Adhesive	3MSJ5009
Screws, HDW PHPHLMS 10-32 x 3/8"	#19084
Strain Relief	HCO1240
Rocker Switch DPST Lighted	MRQ1855.1125-R53
NyLatch Plunger Assembly (Grommet & Plunger)	100-000019
Display PC Board	KL8082
Control PC Board	KL8083
Flow Control Valve Assembly	KL7018
Solenoid Valve Assembly	KL8074
Transformer	KL7057
Sound Foam Kit	KL7076

# Quality Specifications

## Kendall SCD (Sequential Compression Device) Controller (5325)

The following information is a brief description of the test performed on the Kendall 5325 SCD to ensure compliance to the prescribed controller quality specifications and does not include clinical performance.

### 1.0 Electrical Tests

#### 1.1 Display and Control Printed Wiring Board Assemblies.

The boards are tested on a board test fixture for the following functions:

- 1.1.1 Bar graph LED function.
- 1.1.2 Correct sequential activation of ankle, calf, thigh, and vent LED's.
- 1.1.3 Alarm activation button and LED function.
- 1.1.4 Cooling button and LED function.
- 1.1.5 The UP button function.
- 1.1.6 The DOWN button function.
- 1.1.7 Board calibration is confirmed.

#### 1.2 Controller

- 1.2.1 Dielectric Voltage Withstand Test, (Hi-Pot).
- 1.2.2 Power switch function.
- 1.2.3 Indicator lights and button functions.

### 2.0 Pneumatic Functional Tests

- 2.1 Controller calibration at  $45 \pm 2$  mmHg.
- 2.2 Airflow supporting compression in the ankle, calf, and thigh.
- 2.3 System high pressure fault detection.
- 2.4 System low pressure fault detection.

### 3.0 Burn In Requirements

While operating in the Burn In mode, the Controller is run 48 hours to enhance unit reliability.

### 4.0 Visual Attributes Inspection

- 4.1 Case parts appearance and alignment
- 4.2 Labeling

### 5.0 Final Product Inspection

Final release criteria utilizes sampling of Controllers for the following:

- 5.1 Calibration
- 5.2 Air flow levels
- 5.3 Cosmetic defects

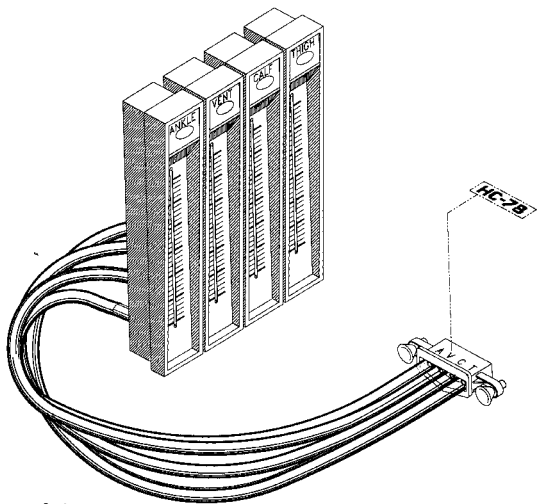

1520-421-8268

219-879-8200  
Dwyer INSTRM  
P/N RMC-101

51.00  
500

**FIGURE 1**



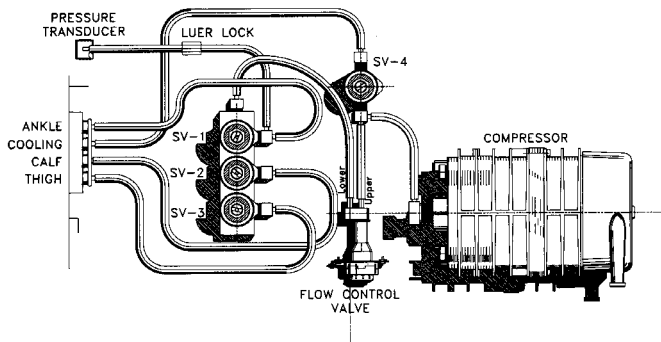

**Pneumatics**  
**FIGURE 2**

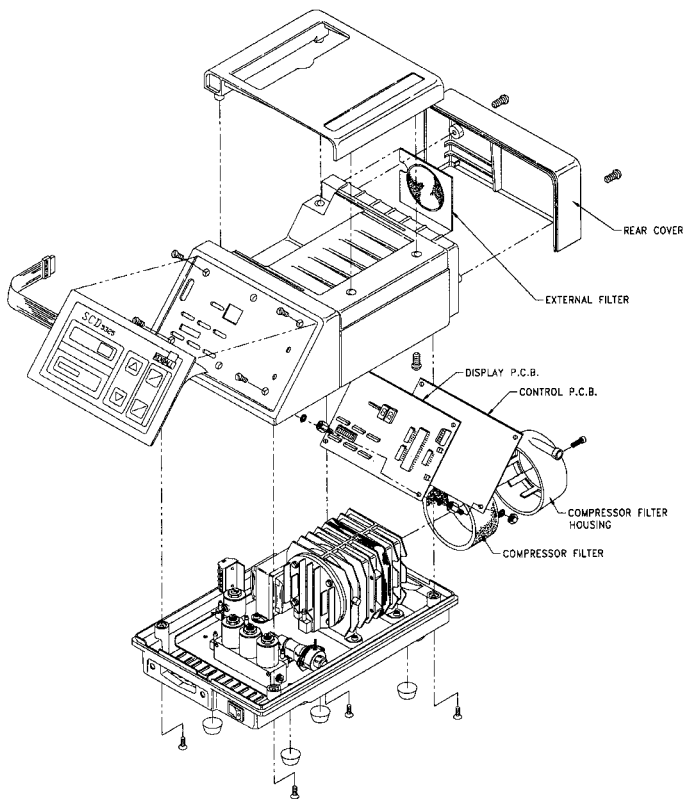

**FIGURE 3**

TUBE LENGTH CHART

NO.	NAME	LENGTH
A	ANKLE PORT	6.5
B	COOL PORT	6.5
C	CALF PORT	6.5
D	THIGH PORT	6.5
E	MANIFOLD SUPPLY	7.5
F	PUMP OUTPUT	3.3
G	VALVE SUPPLY	7.0
H	ANKLE SENSE	6.0
I	PCB SENSE	6.0

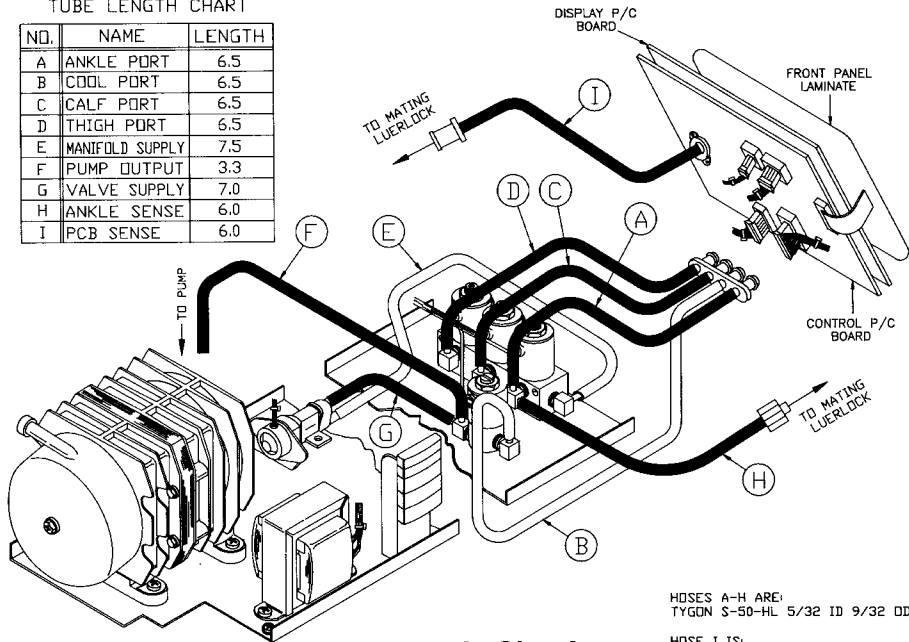

HOSES A-H ARE:  
 TYGON S-50-HL 5/32 ID 9/32 OD

HOSE I IS:  
 TYGON S-50-HL 1/8 ID 1/4 OD

**Pneumatic Circuit**  
**FIGURE 4**

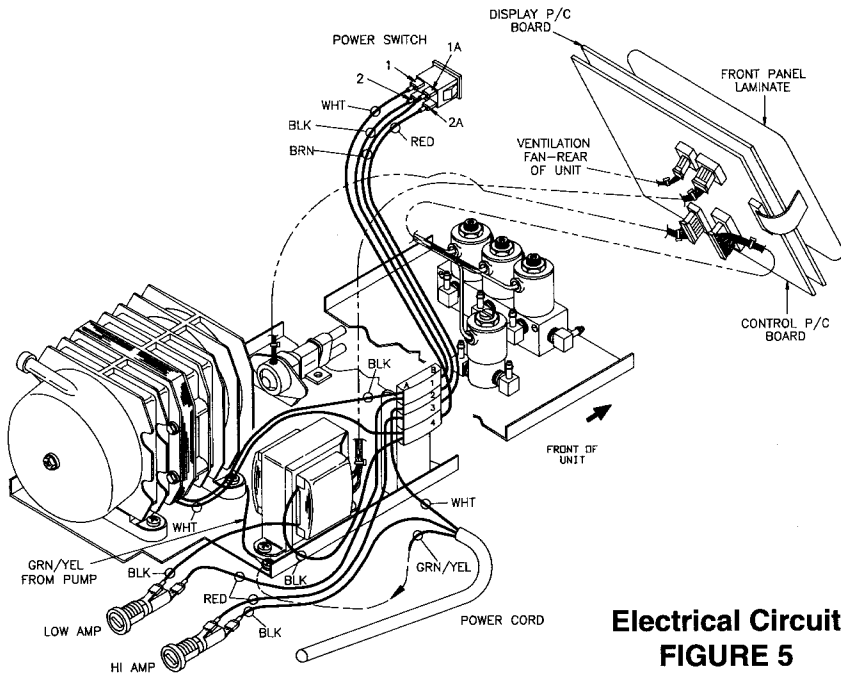

**Electrical Circuit  
FIGURE 5**

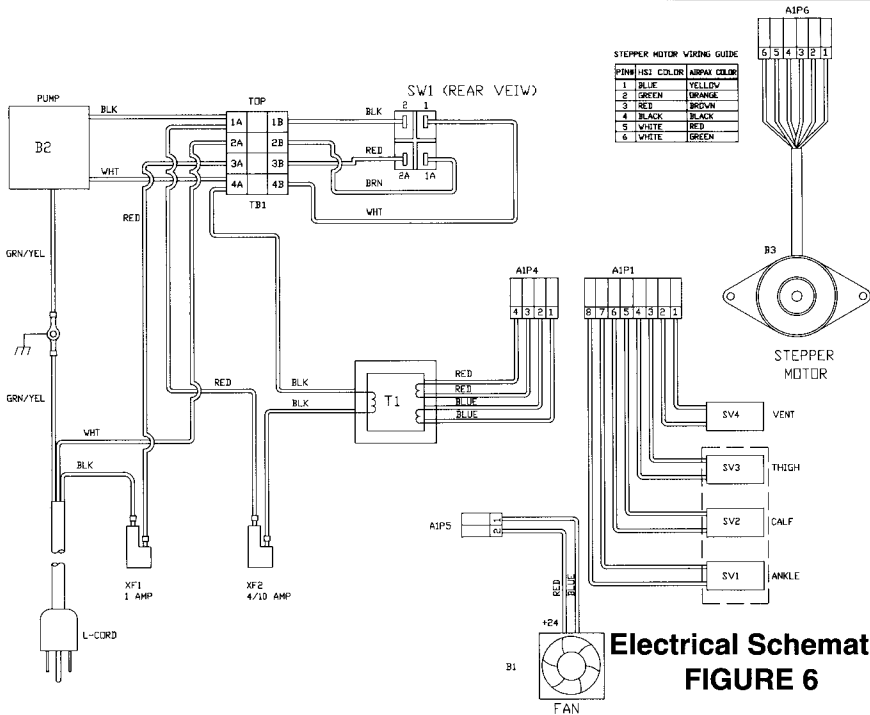

**Electrical Schematic  
FIGURE 6**

# KENDALL MODEL 5325 PARTS LIST

TO PLACE AN ORDER FOR PARTS LISTED HERE:

WRITE

Electronic Assembly Corporation  
585 Enterprise Drive  
ATTN: Kendall Service Dept.  
Neenah, WI. 54956

Rcvd  
01/98

FAX

(920) 751-5499

CALL

(800) 765-4324; Press 1

**EAC accepts credit cards!**

For new SCDs, patient tubing assemblies and sleeves, or to contact your Kendall representative, call Kendall Healthcare Products, Co. at (800) 962-9888. *< BEN BROWN = 800 346-7197 / 8078*

For service on the AV Impulse unit, contact Kendall Healthcare Products, Co. at (800) 421-8268.

There is a \$50.00 minimum required on each order.

Prices are subject to change at any time. All sales are final.

Please use the **Order Part Number** when ordering.

UNIT DESCRIPTION	REFERENCE PART NUMBER	ORDER PART NUMBER	UNIT PRICE
Air Filter Card	KL7065	KL7065	\$ 5.00
Compressor Filter	MDOLP12174	100-000023	\$ 10.00
Compressor (includes fitting)	MDOAC0502 (KL8083)	600-000007	\$ 310.00
Compressor Foot (Mounting)	MDOLA1822D	100-000022	\$ 25.00
Case Handle with Label	KL8085	KL7111	\$ 25.00
Case Back Cover	KL8086	KL7112	\$ 20.00
Case Top w/ Sound Foam Kit	KL8087	KL7109	\$ 55.00
Case Base with Label	KL8088	KL7110	\$ 50.00
Fan Assembly (60mm, 24V)	KL7063	268427	\$ 30.00
Fuse; .4Amp 3AG Sloblo	LF313.400	620-000022	\$ 3.00
Fuse; 1Amp 3AG Sloblo	LF313001	620-000021	\$ 3.00
Fuseholder	LF345611	620-000023	\$ 5.00
Harness Coupling (1 per Cust.)	HC-78	100-000018	\$ 10.00
Insert Nipple (Black) <i>FRONT</i>	KL5822	KL5822	\$ 4.00
Insert Tubing (White) <i>FRONT</i>	KL5820	KL5820	\$ 5.00
Label "Explosion Hazard"	KL7073	KL7284	\$ 2.00

# KENDALL MODEL 5325 PARTS LIST

Label, Fuse	KL7075	KL7075	\$ 2.00
Label, "Maintain Ground"	KL5810	KL5810	\$ 2.00
Membrane Switch	KL7064	KL7064	\$ 80.00
Operating Instructions, w/ Tether	KL7049	KL7049	\$ 10.00
Power Cord, Molded Plug, 13Ft w/ Label and Strain Relief	268424 KL5823	KL7060	\$ 25.00
Rubber Case Foot w/ Adhesive	3MSJ5009	3MSJ5009	\$ 1.00
Screws, 10-32 x 3/8" PHPHLMS	#19084	700-000307	\$ 0.25
Strain Relief	HCO1240	700-000175	\$ 1.00
Rocker Switch DPST Lighted	MRQ1856.1125-R53	610-000067	\$ 17.00
Grommet & Plunger Pin	100-000019	100-000019	\$ 2.00
Grommet Only	100-000020	100-000020	\$ 1.00
Display PCB	KL8082	268403	\$ 115.00
Control PCB	KL8443/268406	KL7262-A	\$ 180.00
Flow Control Valve Assembly	KL8442	268409	\$ 80.00
Solenoid Valve Assembly	KL8074	268423	\$ 125.00
Transformer Assembly	KL7057	268421	\$ 68.00
Operation & Service Manual	KL7051	KL8882	\$ 4.00
Sound Foam - Top	KL7076-010	KL7076-010	\$ 5.00
Sound Foam - Right Side	KL7076-020	KL7076-020	\$ 5.00
Sound Foam - Left Side	KL7076-030	KL7076-030	\$ 5.00

LUER LOCK  
TUBING

700-000464  
700-000332  
700-000274

Post-it <sup>®</sup> Fax Note	7671	Date	1/21/98	Page	7
To	Michael Stokow	From	Michelle Lux		
Co./Dept	Midcom	Co.	EAC		
Phone #	0963 X15	Phone #	800 765 4324		
Fax #	970 587 5104	Fax #	920 751 5499		

SOD 5325

AC0502 A-1017-D2-0511 PARTS LIST PRICE

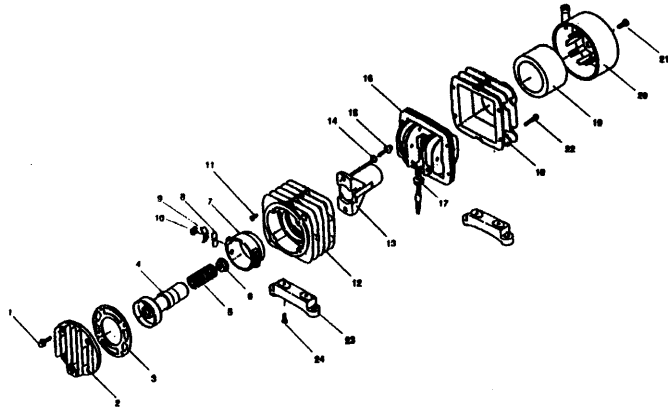

LB03158-0

NO	PART NO	PART NAME	Q'ty	LIST PRICE
1	LP12598-0	HEX.BOLT 5X20	4	\$0.20
2	LP12401-0	HEAD COVER	1	\$20.00
3	LP12595-0	GASKET	1	\$4.00
4	<del>LA07355-0</del>	PISTON ASSY	1	\$50.00
5	LP12154-0	SPRING 2.5X18.2X48	1	\$2.00
6	LP12155-0	SPRING SEAT	1	\$1.50
7	LA07349-0	F-CYLINDER ASSY	1	\$36.00
8	LP10359-0	OUTLET VALVE	2	\$1.00
9	LP13735-0	VALVE RETAINER B	2	\$0.60
10	LP12475-0	SE KING SE-5	2	\$0.10
11	LP08480-0	* SCREW 4X6	1	\$0.20
12	LP12157-0	HOUSING	1	\$40.00
13	LA71843-0	REAR CYLINDER ASSY	1	\$37.00
14	LP10355-0	INSULATION BUSH	2	\$0.50
15	LP12590-0	*SCREW 5X20	2	\$0.30
16	LA07351-0	FIELD CORE ASSY	1	\$101.40
17	LP11070-0	BUSH	1	\$0.60
18	LP12153-0	END CAP	1	\$20.00
19	LP12174-0	AIR FILTER ELEMENT	1	\$2.90
20	LP12173-0	AIR CLEANER COVER	1	\$4.00
21	LQ00191-0	*SCREW 5X15	1	\$0.16
22	LP12600-0	*SCREW 5X30	4	\$0.30
23	LA71622-0	RUBBER FOOT	2	\$7.00
24	LP30898-0	*SCREW 4X12	4	\$0.20